



**MATCON**<sup>®</sup>

POWDERS, HANDLED.

# IBCs - INTERMEDIATE BULK CONTAINERS

EFFICIENT HANDLING OF  
BULK POWDER SOLIDS.

IBC solutions for effective powder  
containment, transfer and processing.

---

[www.matconibc.com](http://www.matconibc.com)

# The Original Cone Valve IBC Manufacturers

Matcon supply a range of IBCs for the processing, storage and transport of bulk material solids, powders, granules and tablets.

Our unique Cone Valve technology within each IBC prevents the traditional powder handling issues of bridging, blocking and blend segregation.

MATCON CONE VALVE IBC TECHNOLOGY

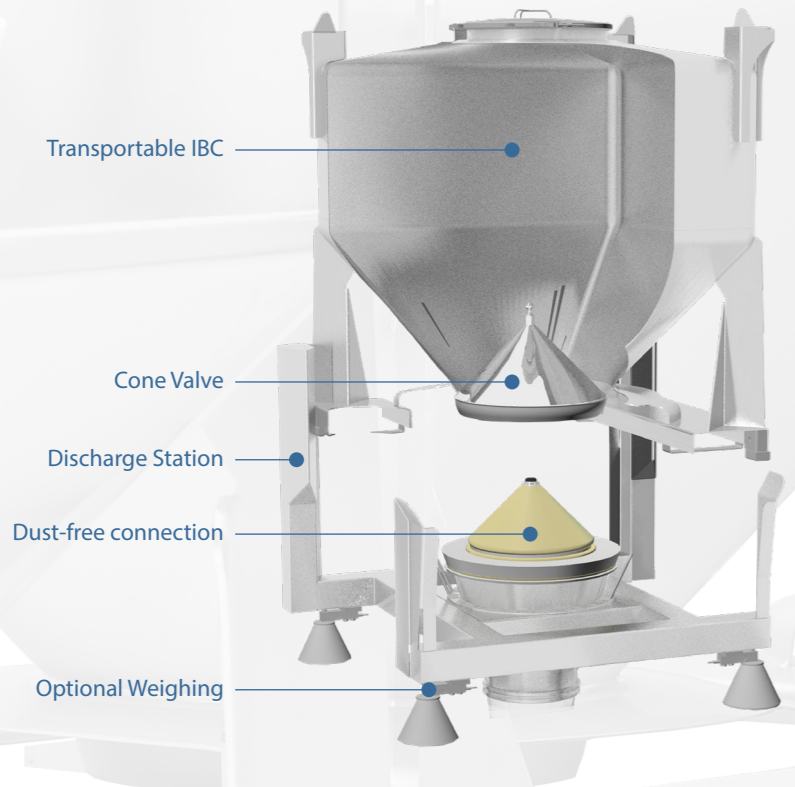

## THE CONE VALVE IBC ADVANTAGE

- Guaranteed powder flow
- Control of flow
- Prevent segregation
- Automated discharging procedure
- Complete discharge
- Dust-free handling
- Easy-clean, hygienic design
- Direct dosing, no secondary feeders

Designed to meet the highest hygiene and safety requirements, each IBC is manufactured with no enclosed crevices or hollow sections that could trap product or contaminants.



Efficient and dust-tight, they provide a system that lives up to the most rigorous of standards.

The Matcon IBC is manufactured from 316L stainless steel or 304 stainless steel, dependent upon the application.

**300 - 500 Litres** - Small IBC for smaller batch sizes or testing purposes.

**1,000 - 2,000 Litres** - Most commonly used range of IBC batch sizes.

**2,500 - 3,500 Litres** - Large scale IBC to match larger batch requirements.

### Key Benefits

- Sizes range from 300L to 3500L+ capacity
- Prevents segregation with mass flow discharge
- Fully contained, dust-free handling
- Complete, controlled discharge
- Hygienic, easy to clean design
- Easy handling with Forklifts, AGVs & Straddle Trucks
- Direct dosing from the IBC without ancillary device

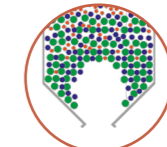
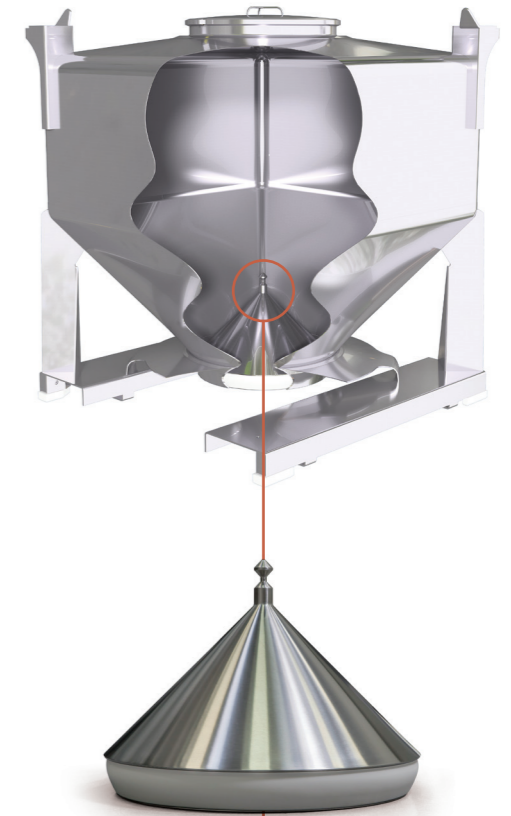

BRIDGING

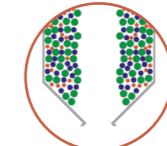

RAT-HOLING

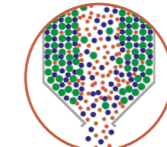

SEGREGATION

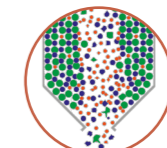

DEGRADATION

AVOID THESE POWDER HANDLING ISSUES

# MATCON®

POWDERS, HANDLED.

We specialise in providing complete materials handling solutions in the Food, Nutrition, Pharmaceutical and Chemical sectors.

We're not just an IBC provider, but a true partner helping you accomplish the right system for your needs.



THE POWDER HANDLING EXPERTS

[www.matconibc.com](http://www.matconibc.com)

MATCON, Bramley Drive, Vale Park West, Evesham, Worcestershire, WR11 1JH, UK

Tel: +44 (0) 1386 769 000 Fax: +44 (0) 870 191 1116



Material Processing Technologies