

DÉTAIL C
ECHELLE 2 : 15

DÉTAIL D
ECHELLE 2 : 15

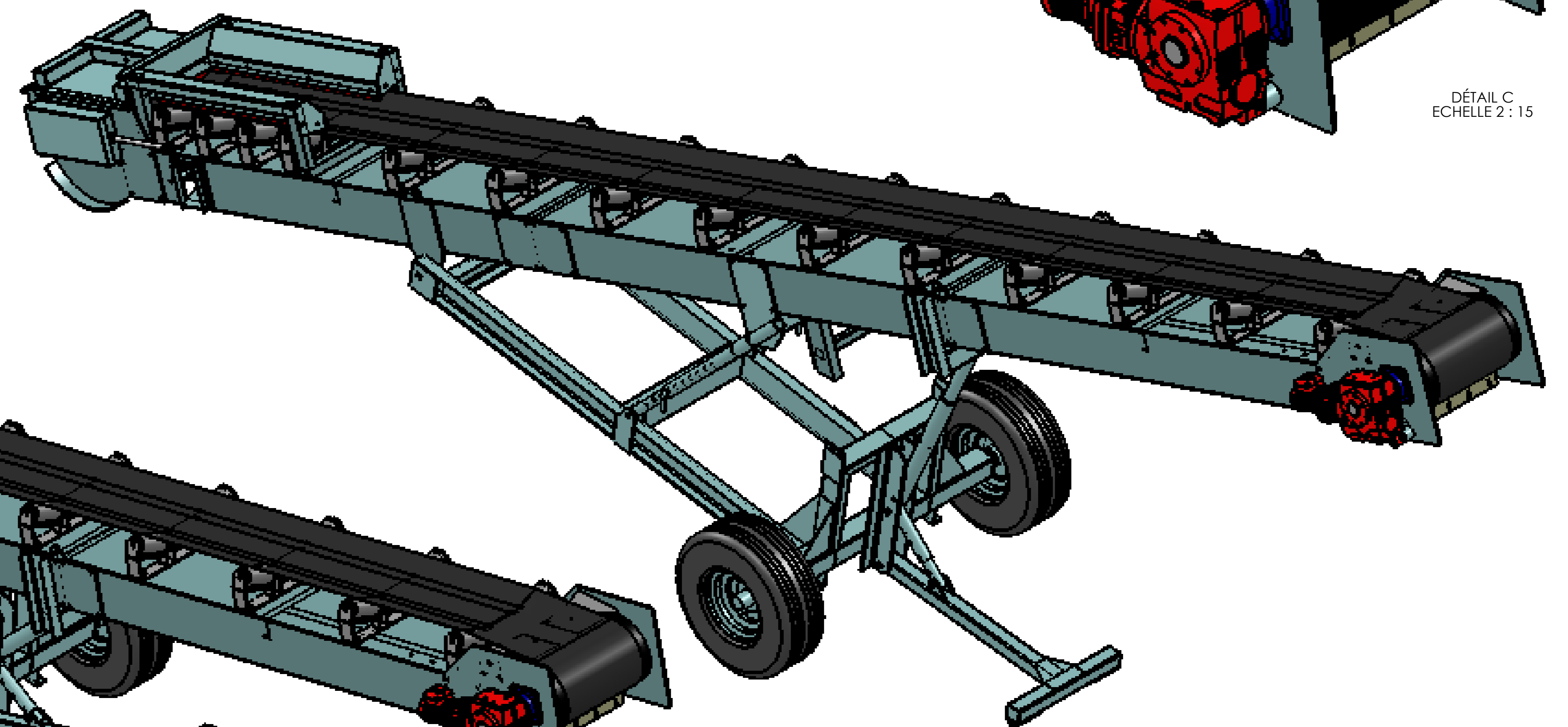
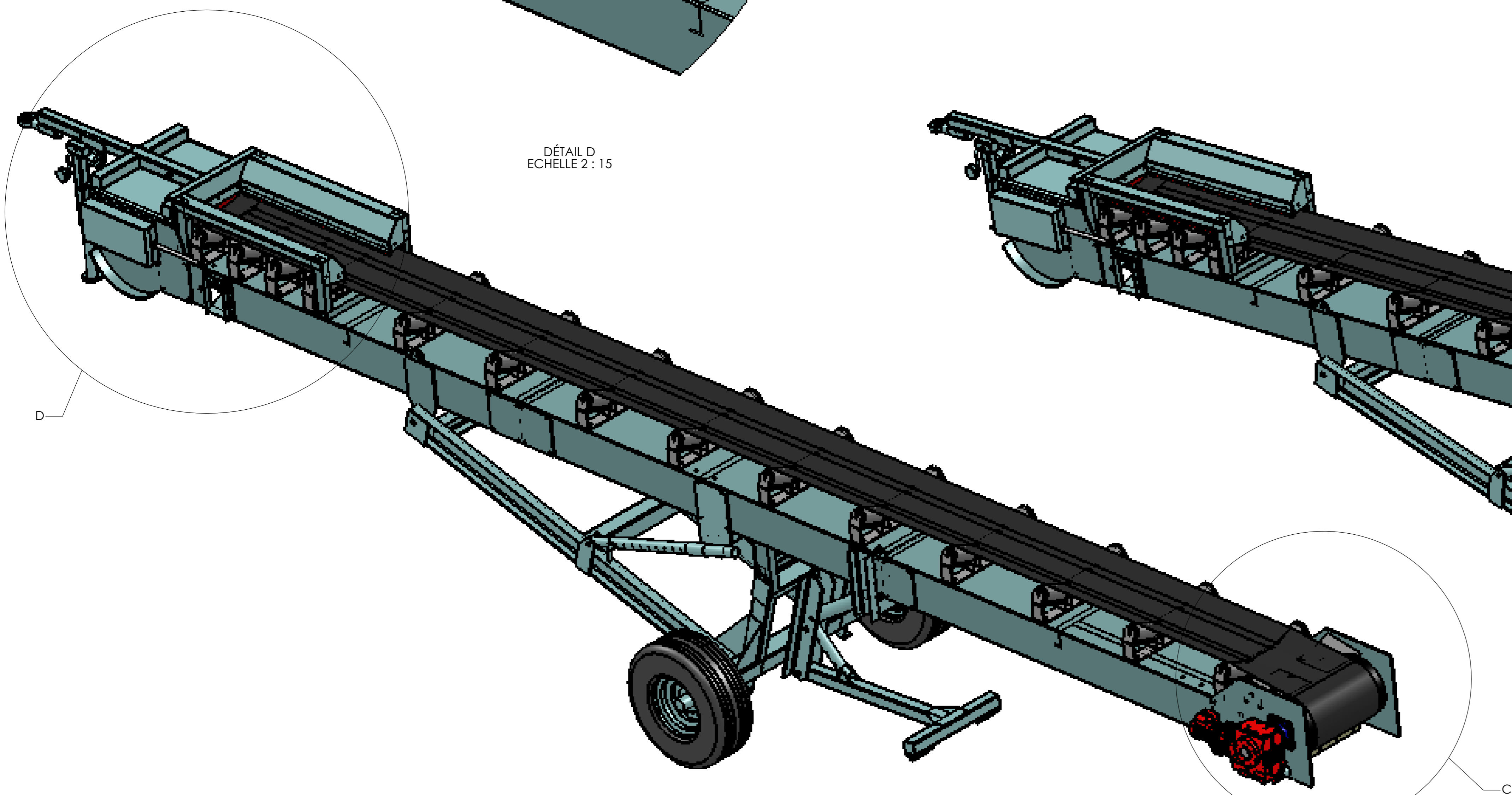

Modification	Date	Elabli	Vérifié	Date	Approuvé	Rev.
CERIP Conception - Etudes - Réalisations Industrielles - Provençales Quartier Tengué 3306 B Route de Gordes 84440 ROBION Tel : 04 90 76 58 55 / Fax : 04 90 76 58 22 / E-Mail : cerip@cerip.fr						
<small>Tolérances générales : Débr/Forerie : ± 1mm / Angle de pliage <math>\le 45^\circ</math> - Assemblage par soudure : de 0 à 1000 : 1mm / de 1000 à 6000 : 3mm Tolérances générales d'usinage : de 0 à 30 mm : ± 0.2 / > 30 mm H11 h11 Rugosité générale : Ra 1.6 - 6.3</small>						
<small>Matière: ACIER S235</small>		<small>Traitement: Peinture PU</small>		<small>RAL: 1015</small>		<small>Masse (Kg) : 1743.88</small>
<small>CLIENT: NGE GUNTOLI</small>						<small>Quantité : 1</small>
<small>DESIGNATION: CONVOYEUR A BDE EN AUGÉ type CBS03</small>						<small>Rep : 02</small>
<small>PLAN DE: ENSEMBLE</small>						<small>Des : JPD</small>
<small>Ech : 1:15</small>						<small>Le : 22-06-16</small>
<small>N°: C4629-02.00.00</small>						<small>N°: C4629-02.00.00</small>

Ce document est la propriété de CERIP, il ne peut être ni copié, ni communiqué à des tiers sans l'autorisation de la société CERIP